

FORMULAS CON GUIA INFERIOR SUPERPUESTA

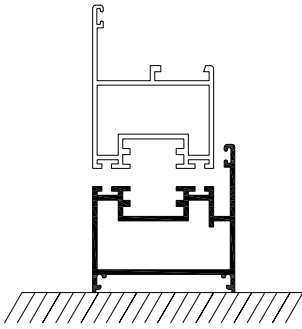

Z = Altura de las hojas obtenida mediante formula

N = Numero de hojas que componen la plegable

H = Altura de hueco

L = Ancho de hueco

¡¡ Medidas de corte (mm) !!

 Marco lateral (Ref: 4713) : H -35

 Marco superior (Ref: 4711) : L

 Marco inferior (Ref: 4713) : L

 Hojas verticales (Ref: 4714) : H - 90

 Batiente (Ref: 4715) : Z - 5

 Hojas horizontales: $\frac{L - 76 - (6 * N)}{N}$

FORMULAS CON GUIA INFERIOR EMPOTRADA

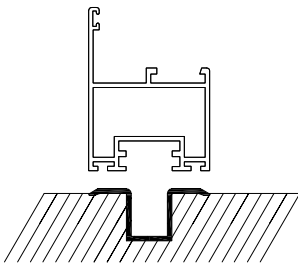

Z = Altura de las hojas obtenida mediante formula

N = Numero de hojas que componen la plegable

H = Altura de hueco

L = Ancho de hueco

¡¡ Medidas de corte (mm) !!

 Marco lateral (Ref: 4713) : H -37

 Marco superior (Ref: 4711) : L

 Marco inferior (Ref: 4718) : L

 Hojas verticales (Ref: 4714) : H - 57

 Batiente (Ref: 4715) : Z - 5

 Hojas horizontales: $\frac{L - 76 - (6 * N)}{N}$